

# Instruction Manual

## Art.-No. 0556 0104

Info-Hotline:  
 Tel. 04181 203803 – Fax 04181 203804 – Email: [Kowalski.bub@t-online.de](mailto:Kowalski.bub@t-online.de)  
 B+B Thermo-Technik GmbH, Heinrich-Hertz-Str. 4, 78166 Donaueschingen  
 Tel. 0771 8316-0, Fax 0771 8316-50, Email: [info@bubthermo.de](mailto:info@bubthermo.de),  
[www.temperatur-shop.de](http://www.temperatur-shop.de)



# N1100HC CONTROLLER

## HEAT/COOL PROCESS CONTROLLER - V2.0x

### 1 MAIN FEATURES

- Universal multi-sensor input without hardware change.
- Sensor break protection in any condition.
- Control outputs: relay, linear 4-20mA, 0-20mA, pulsed output
- 2° control output for refrigeration, with independent proportional band and cycle time.
- Overlap adjustment for the control outputs.
- Up to 4 alarms. Up to 2 timer relay alarms.
- Process Variable or Setpoint 4-20mA or 0-20mA analog retransmission.
- Auto/Manual "bumpless" transfer.
- Up to 3 digital inputs with 5 programmable functions.
- Programmable Soft Start (0 to 9999 seconds).
- RS-485 digital communication; RTU MODBUS protocol.
- Unique electronic 8-digit serial number can be viewed at the display.
- Firmware version displayed during power up.
- Keyboard password protection.

### 2 SPECIFICATIONS

- Dimensions: 48x48x110mm (1/16 DIN).
- Approximate weight: 150g
- Panel cut-out: 45,5x45,5 mm (+0.5 -0.0mm)
- Terminal connection: 18 screws accepting 6.3 mm fork lugs.
- Power: 85 to 250Vac/dc, 50/60Hz. Max. Consumption: 3VA
- Operating environment: 0 to 55°C, humidity: 20 to 95%

#### INPUT

- Keyboard selection of input type (refer to table 1)
- Internal resolution: 19500 levels
- Display resolution: 12000 levels (from -1999 to 9999)
- Input sample rate: 5 per second
- Accuracy: Thermocouples J, K and T: 0.25% of span  $\pm 1^\circ\text{C}$   
 Thermocouple S: 0.25% of span  $\pm 3^\circ\text{C}$   
 Pt100: 0.2% of span  
 4-20mA, 0-50mV, 0-5Vdc: 0.2% of span.
- Input impedance: 0-50mV, Pt100 and thermocouples:  $>10\text{M}\Omega$   
 0-5V:  $>1\text{M}\Omega$   
 4-20mA:  $100\Omega$
- Pt100 measurement: DIN 43760 standard ( $\alpha=0.00385$ ).  
 Excitation current:  $170\mu\text{A}$ . 3-wire circuit, cable resistance compensation.

- Analog output: 0-20mA or 4-20mA, 1500 levels, 550 $\Omega$  max.
- Second analog input: 4-20mA remote set point (standard). This feature requires an external shunt resistor, provided with the instrument, to be connected to terminals 9 and 10.

#### CONTROL OUTPUT (Standard Version (up to 3 outputs):

- Two 3A / 250Vac Relays (3A / 30Vdc);
- Isolated 0-20mA or 4-20mA control output or PV or SP retransmission, 1500 level resolution, 550 $\Omega$  max. Load;
- Logic pulse for SSR drive: 0 or 20mA;
- Any of the above and options 1 and 2 can be selected as the main control output and the remaining outputs can be set as alarms;
- Programmable PWM cycle from 0.5 sec. and 100 sec.;
- Start up 3 seconds after power up;

#### With Option Modules (up to 5 outputs)

- Option 1: 3A / 250Vac (3A / 30Vdc) SPDT Relay (3rd relay);
- Option 2: two digital I/Os (input: dry contact; output 5Vdc, 10mA max.). Option 3: heater break detection;
- Option 4: RS-485, MODBUS RTU protocol, 1200 to 19200bps;

#### ALARMS

- Up to 4 alarms can be set with 9 different functions for each one. Other alarm features are:
- 2 Timing alarms, programmable from 0 to 6500 sec., with advanced functions, ideal for servo-positioning
- Independent power-up inhibition of the 4 alarms
- Programmable hysteresis for the 4 alarms

### 3 OPERATION

The front panel is shown in Figure 1.

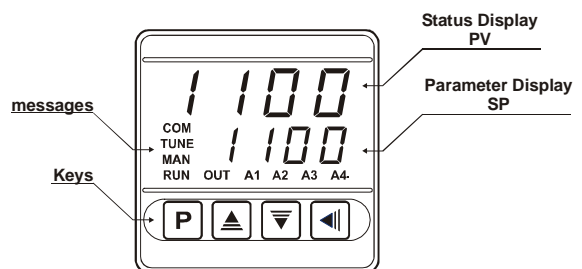

Figure 1 - Front panel parts

**Status display/PV:** shows the value of PV (Process Variable). When in programming mode, shows the parameter name.

**Parameter display/SV:** shows the SV (Setpoint Variable) value and the value of other parameters of the controller.

**COM Indicator:** Flashes when communication messages are sent by the controller.

**TUNE Indicator:** Lights during the execution of PID automatic tuning.

**MAN Indicator:** Lights when the controller is in manual.

**RUN Indicator:** Lights when the controller is active, with control and alarm outputs enabled.

**OUT Indicator:** For relay or pulse control output, reflects the actual state of the output. If an analog output is assigned for control, lights continuously.

**A1, A2, A3 and A4 Indicators:** Status of the alarms.

**[P]** - **PROG key:** used to walk through the menu cycles

**[◀]** - **BACK key:** go back to the previous displayed parameter

**[▲]** - **INCREASE** and **[▼]** - **DECREASE keys:** Used to change parameter values

When the controller is turned on, its firmware version is displayed for 3 seconds, after which the controller starts normal operation. The values of PV and SV are displayed and the outputs are enabled.

Before the controller is ready to be used in a given process, it requires some basic configuration, such as:

- input type (TC, Pt100, 4-20mA, ...) at the "tTYPE" prompt, according to table 1;
- output type (relay, 0-20mA, 4-20mA or pulse) at "I/O 1", "I/O 2",... "I/O 5" prompts (see Table 2);
- setpoint variable SV. Set the remaining parameters.
- PID parameters (or hysteresis for ON/OFF control)

Other functions, including alarms, ramp and soak, timer, digital input, etc., may be useful for a better system performance.

The parameters are grouped in 7 cycles.

Cycle	Access
1- Operation	Free access parameters *
2- Tuning	Reserved access parameters **
3- R&S Program	
4- Alarms	
5- Input Configuration	
6- I/Os	
7- Calibration	

\*These parameters can be viewed but not changed if the cycle is protected.

\*\*Requires a key combination to access the cycle.

Press **[P]** to advance and **[◀]** to go back in the menu cycle.

Keep pressing the **[P]** or **[◀]** key to move fast forward or backward.

Press **[◀]** and **[P]** simultaneously to move from one cycle to the next one.

At the end of each cycle the controller returns to the operation cycle.

## 4 PROGRAM SECURITY

Each menu cycle can be locked (protected) by pressing **[◀]** and **[▲]** simultaneously for 3 seconds. Press **[◀]** and **[▼]** for 3 seconds to unlock. A short blink of the display confirms the lock/unlock change. This will alternately lock or unlock the **[▲]** and **[▼]** keys to avoid tampering.

For further protection, the unlock operation through the keypad may be disabled by changing the position of an internal strap inside the controller:

When **PROT** is **OFF**, the user is allowed to lock and unlock the cycles using the keypad as explained above. If **PROT** is **ON**, the cycles lock/unlock operation is disable.

## 5 CONFIGURATION:

### 5.1 INPUT TYPE SELECTION

Select the input type (in parameter "tTYPE") from Table 1 below.

Table 1 - Input Types

TYPE	CODE	CHARACTERISTICS
J	0	range: -50 to 760 °C (-58 to 1400°F)
K	1	range: -90 to 1370 °C (-130 to 2498°F)
T	2	range: -100 to 400 °C (-148 to 752°F)
N	3	range: -90 a 1300 °C (-130 a 2372°F)
	4	inaccessible
S	5	range: 0 to 1760 °C (32 to 3200°F)
Pt100	6	range: -199.9 to 530.0 °C (-328.0 to 986.0°F)
Pt100	7	range: -200 to 530 °C (-328 to 986°F)
4-20 mA	8	J linearization. Programmable range: -110 to 760°C
4-20 mA	9	K linearization. Programmable range: -150 to 1370°C
4-20 mA	10	T linearization. Programmable range: -160 to 400°C
4-20 mA	11	N Linearization. Faixa prog.: -90 a 1370°C
4-20 mA	12	R Linearization. Faixa prog.: 0 a 1760°C
4-20 mA	13	S linearization. Programmable Range: 0 to 1760°C
4-20 mA	14	Pt100 linearization. Prog. Range:-200.0 to 530.0°C
4-20 mA	15	Pt100 linearization Prog. Range:-200 to 530°C
0 to 50mV	16	Linear. Programmable indication -1999 to 9999
4-20 mA	17	Linear. Programmable indication -1999 to 9999
0 to 5Vdc	18	Linear. Programmable indication -1999 to 9999

### 5.2 OUTPUTS, ALARMS AND DIGITAL INPUTS CONFIGURATION

The controller input/output channels can assume multiple functions, depending on configuration: control output, alarm output, digital output, digital input, and PV or SV analog retransmission. This channels are identified as I/O1, I/O2, I/O3, I/O4 and I/O 5.

The basic controller model comes loaded with:

- I/O1 - relay output
- I/O2 - relay output
- I/O5 - analog output (0-20 or 4-20mA), pulse, digital I/O

The options available are:

- I/O3 - 3rd relay (option 1)
- I/O3 and I/O4 - 2 digital input/output (option 2)
- Heater break protection (option 3).

The function code of each I/O can be selected among the options on Table 2. Only valid function codes are displayed for each I/O (for example, I/O1, which is a relay, can be configured with functions 0 to 5 only; on the other hand, I/O5 can perform all 16 functions).

The description for the functions follows:

- CODE 0 - No function. The I/O channel programmed with code 0 will not be used by the controller. It is available to be used by serial communication as digital output.
- CODES 1 to 4 - Alarm output - Available for all I/O channels. The selected channel can be used as output to Alarms 1 to 4.
- CODE 5 - PWM control 1 output - Available for all I/O channels.
- CODE 6 - PWM control 2 output - Available for all I/O channels.
- CODE 7 - Digital input - Standard for I/O5 and optional for I/O3 and I/O4.

Closed : Manual control  
Opened: Automatic control

- CODE 8 - Digital input - Standard for I/O5 and optional for I/O3 and I/O4. Start/Stop input ("rvn" : YES / no).  
 Closed : outputs enabled  
 Opened: outputs disabled

Table 2 - I/O channel functions

CODE	I/O Type	I/O Function
0	Digital Output	Digital Output to be set by the serial comm.
1	Digital Output	Alarm 1 Output
2	Digital Output	Alarm 2 Output
3	Digital Output	Alarm 3 Output
4	Digital Output	Alarm 4 Output
5	Digital Output	PWM Control 1 Output
6	Digital Output	PWM Control 2 Output
7	Digital Input	Automatic/Manual mode change
8	Digital Input	Run/Stop mode change
9	Digital Input	inaccessible
10	Digital Input	Executes/Holds selected ramp and soak profile
11	Digital Input	Enable/Disable R&S profile 1 selection
12	Analog Output	4 a 20mA Analog control 1 output
13	Analog Output	0 a 20mA Analog control 1 output
14	Analog Output	4 a 20mA PV retransmission
15	Analog Output	0 a 20mA PV retransmission
16	Analog Output	4 a 20mA SP retransmission
17	Analog Output	0 a 20mA SP retransmission
18	Analog Output	4 a 20mA Analog control 2 output
19	Analog Output	0 a 20mA Analog control 2 output

- CODE 9 - inaccessible
- CODE 10 - Digital input - Standard for I/O5 and optional for I/O3 and I/O4.  
 Opened: enables R&S program  
 Closed: holds R&S program (the program resumes when the contact is opened again)
- CODE 11 - Digital input - Standard for I/O5 and optional for I/O3 and I/O4. Selects R&S program 1. Used to alternate between the main Setpoint and a second Setpoint defined by the R&S program 1.  
 Closed : selects program 1  
 Opened: uses main Setpoint
- CODE 12 - Analog control 1 output - I/O5 only. 4-20mA control output.
- CODE 13 - Analog control 1 output - I/O5 only. 0-20mA control output.
- CODES 14 to 17 - Analog retransmission. I/O5 only. Configures I/O5 to output a 4-20mA or 0-20mA analog signal proportional to PV or SP.
- CODE 18 - Analog control 2 output - I/O5 only. 4-20mA control output.
- CODE 19 - Analog control 2 output - I/O5 only. 0-20mA control output.

**5.3 ALARM CONFIGURATION**

The controller has 4 alarms. Only alarms 1 and 2 have front panel lamps associated to them.

The alarms can be configured to operate in any of the nine functions listed on Table 3.

**5.4 ALARM TIMER FUNCTIONS**





Alarms 1 and 2 can be programmed to have timer functions. The 3 modes of operation are:

- pulse
- delayed actuation
- oscillator

The desired function can be achieved programming the parameters "A1t1", "A1t2", "A2t1" and "A2t2" (see Table 4).

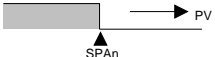

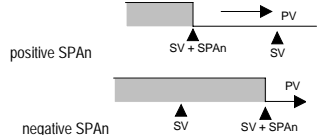
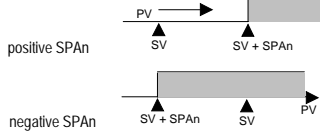
The LEDs associated to the alarms will light when the alarm condition is recognized, not following the actual state of the output, which may be temporarily OFF because of the temporization.

Table 3 - Alarm functions

TYPE	PROMPT	ACTION
Disabled	<b>off</b>	No active alarm. This output can be used as a digital output to be set by the serial communication.
Sensor Break (input Error)	<b>i err</b>	Alarm will be ON if PV sensor breaks, input signal is out of range or Pt100 is shorted.
Event Alarm (ramp and Soak)	<b>rs</b>	Can be activated at a specific segment of ramp and soak program.
Heater break detection resistance fail	<b>rfal l</b>	Detects a heater broken condition
Low Alarm	<b>lo</b>	
High Alarm	<b>ki</b>	
LOW Differential	<b>di fl</b>	
HIGH Differential	<b>di fk</b>	
Differential	<b>di f</b>	

where SPAn means "SPA1", "SPA2", "SPA2" and "SPA4".

Table 4 - Advanced Timer Alarm (for alarms 1 or 2):

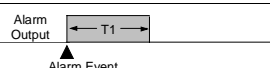
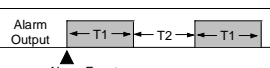
Alarm Function	T1	T2	ACTION
Normal	0	0	
Delayed	0	1s to 6500s	
Pulse	1s to 6500s	0	
Oscillator	1s to 6500s	1s to 6500s	

**5.5 ALARM INITIAL BLOCKING**

The initial blocking option inhibits the alarm from being recognized if an alarm condition is present when the controller is first energized. The alarm will actuate only after the occurrence of a non alarm condition followed by a new occurrence for the alarm.

The initial blocking is disabled for the **sensor break** alarm function.

### 5.6 ANALOG RETRANSMISSION OF PV AND SP

The analog output, when not used for control purposes, is available for retransmitting the SV and SP values in 0-20 or 4-20mA. This analog output is electrically isolated from other inputs and outputs.

The analog output signal is scaleable, with the output range determined by the values programmed in the parameters "SPLL" and "SPkL".

To obtain a voltage output, connect a resistor shunt to the current output terminals (terminal 7 and 8).

### 5.7 SOFT-START

Define o intervalo de tempo para que a saída de controle 1 possa atingir o seu valor máximo. O valor de saída do controle 1 varia progressivamente de 0 a 100% no intervalo de tempo programado na tela "SFSt".

O *Soft-start* é normalmente utilizado em processos que requeiram partida lenta, onde a aplicação de 100% de potência no início da operação podem comprometer o sistema.

A saída de controle 1 é determinada principalmente pela malha de controle PID. O *Soft-start* simplesmente limita essa saída. Ver também os parâmetros "o111" e "o1kl".

## 6 INSTALLATION

Insert the unit into the panel cut-out and slide the mounting clamp from the rear to a firm grip at the panel.

### 6.1 ELECTRICAL CONNECTIONS

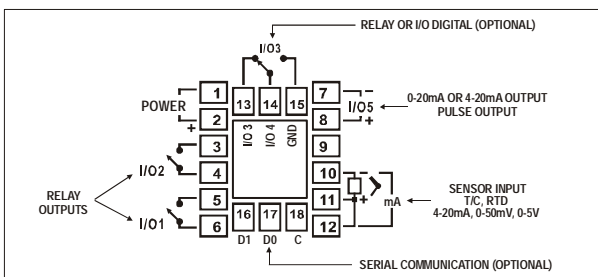
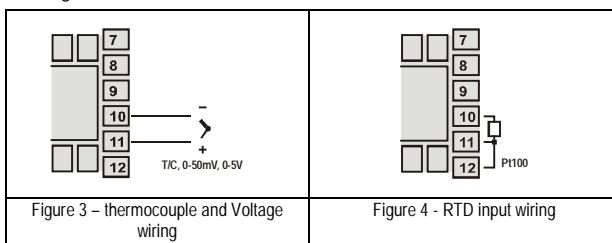

Figure 2 - Backpanel terminals

- Thermocouple and voltage (Volts and mV) input connect as in Figure 3.



- RTD (Pt100)  
Figure 4 shows the Pt100 wiring, for 3 conductors. Terminals 10, 11 and 12 must have the same wire resistance for proper cable length compensation. For 2 wire Pt100, short circuit terminals 11 and 12.

- 4-20mA  
Refer to Figure 5. (The controller provides an internal electronic shunt for the input current. No changes in the circuit are necessary).

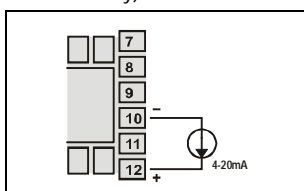

Figure 5 - Input current wiring

- Digital Input  
Use channels I/O3, I/O4 or I/O5 as digital inputs. See also explanations on section 5.2

## 7 CONFIGURATION PARAMETERS

### 7.1 OPERATION CYCLE

PV Indication (Red)	PV AND SV INDICATION: The status display shows the present value of PV (Process Variable). The parameter display shows SV (Set Variable).  The status display shows " - - - " whenever PV exceeds the maximum range or there is no signal at the input. In case of hardware error the status display will show <b>Ern</b> , where n is the error code.
SV Indication (Green)	
avto	CONTROL MODE: <b>YES</b> indicates automatic control mode (closed loop, PID or ON/OFF). <b>NO</b> indicates manual control mode (open loop). Bumpless transfer from auto ↔ to manual mode is available. If in doubt program <b>YES</b> .
PV Indication (Red)	MANIPULATED VARIABLE VALUE (MV): The upper display shows PV value and the lower display shows the percentage of MV applied to the control output. When in manual control the MV value can be manually changed. When in auto mode the MV value can only be viewed.  To distinguish the MV display from the SV display, the MV is shown flashing intermittently.
MV Indication (Green)	
Pr n	RAMP AND SOAK PROGRAM SELECTION: Selects the ramp and soak program to be executed (4 programs possible). Refer to chapter 7 for R&S description.
rvn	CONTROL ENABLE: <b>YES</b> means that the control output and alarms are enabled and <b>NO</b> means they are disabled.

### 7.2 AUTO TUNING CYCLE 1

atvn	AUTO-TUNE: <b>YES</b> enables the auto tuning of the PID parameters and <b>NO</b> disables it.
Pb1	PROPORTIONAL BAND: Percentage of maximum input span. Select zero for ON/OFF control.
xyst	CONTROL HYSTERESIS (in engineering units): This parameter is only shown for ON/OFF control (Pb=0).
'ir'	INTEGRAL RATE: Integral time constant in repetitions per minute (Reset).
dt	DERIVATIVE TIME: Derivative time constant, in seconds.
(t1	CYCLE TIME: PWM period in seconds. Can only be viewed if proportional band is other than zero.
act	CONTROL ACTION: For Auto Mode only. <ul style="list-style-type: none"> <li>Reverse Action <b>re</b> usually used for heating.</li> <li>Direct Action <b>dir</b> usually used for cooling.</li> </ul>
ovll	OUTPUT LOW LIMIT: minimum percentage value for MV (Manipulated Variable) when in automatic control and PID. Default value: 0.0%
ovxl	OUTPUT HIGH LIMIT: Maximum percentage value for MV when in automatic control and PID. Default value: 100.0%

sfst	SOFT START: Time in seconds during which the controller limits the MV value progressively from 0 to 100%. It is enabled at power up or when the control output is activated. If in doubt set zero.
Spa1	ALARM 1 PRESET: Tripping point for alarm 1.
Spa2	ALARM 2 PRESET: Tripping point for alarm 2.
Spa3	ALARM 3 PRESET: Tripping point for alarm 3.
Spa4	ALARM 4 PRESET : Tripping point for alarm 4.

7.3 CONTROL # 2 PARAMETERS

Pb2	PROPORTIONAL BAND: Percentage of maximum input span. Select zero for ON/OFF control.
Olap	(overLAP): defines the overlap between the heat and cool outputs. The overlap is given in engineering units of the input type used.  When the overlap value is negative, it represents the value of the dead-band instead.  If PB2=0, the overlap parameter is changed to represent the hysteresis value for control #2.
[t2	CYCLE TIME: PWM period in seconds. Can only be viewed if proportional band is other than zero.
A[t2	CONTROL ACTION: For Auto Mode only. <ul style="list-style-type: none"> <li>Reverse Action <b>rE</b> usually used for heating.</li> <li>Direct Action <b>di r</b> usually used for cooling.</li> </ul>
02I I	OUTPUT LOW LIMIT: minimum percentage value for MV (Manipulated Variable) when in automatic control and PID. Default value: 0.0%
02kl	OUTPUT HIGH LIMIT: Maximum percentage value for MV when in automatic control and PID. Default value: 100.0%

7.4 RAMP AND SOAK PROFILE PROGRAMMING CYCLE

Pr n	PROGRAM TO BE VIEWED: Selects the ramp and soak profile program to be edited/viewed in the following cycle prompts (4 programs available).
ptol	RAMP AND SOAK TOLERANCE: maximum deviation between PV and SV. Whenever this deviation is exceeded the time counter is halted until deviation lowers to within the tolerance. Set zero to disable this function.
Psp0 Psp5	RAMP AND SOAK SET POINTS (0 to 5): Set of 6 SV values which define the ramp and soak profile segments. See also PT1 to 5 and PE1 to 5 below.
Pt1 Pt5	RAMP AND SOAK SEGMENTS TIME (1 to 5): Set of 5 time intervals in minutes (9999 max.) for the 5 segments of the ramp and soak program.
Pe1 Pe5	RAMP AND SOAK EVENT (1 to 5): Set of 5 values that define which alarms must be activated during a ramp and soak program segment. Alarm function depends on "rs" setting (Table 3).
lp	LINK TO PROGRAM: Number of the next profile program to be linked to follow the current profile. Profiles can be linked to make larger programs of up to 20 segments.

7.5 ALARM CYCLE

Fva1	ALARM 1 FUNCTION: Select options from Table 3.
Fva2	ALARM 2 FUNCTION: Select options from Table 3.
Fva3	ALARM 3 FUNCTION: Select options from Table 3.

Fva4	ALARM 4 FUNCTION: Select options from Table 3.
bl a1 bl a2 bl a3 bl a4	ALARM BLOCK 1 TO 4: This function blocks the alarm at power-up when the units is first energized. <b>YES</b> enables and <b>NO</b> inhibits this blocking function. When enabled the alarm will not be active at power-up waiting for PV (Process Variable) to reach a non-alarm situation. From this point on the alarm will be free to actuate should a new alarm situation occur.
xya1	ALARM 1 HYSTERESIS: Defines the differential range between the PV value at which the alarm is turned on and the value at which it is turned off (in engineering units).
xya2	ALARM 2 HYSTERESIS: Same as above.
xya3	ALARM 3 HYSTERESIS: Same as above.
xya4	ALARM 4 HYSTERESIS: Same as above.
A1t1	ALARM 1 TIME 1: Defines the time (6500 sec. max.) during which the alarm 1 output will be <b>ON</b> when alarm 1 is active. Program zero to disable this function.
A1t2	ALARM 1 TIME 2: Defines the <b>OFF</b> state time for the alarm 1 output, after being <b>ON</b> during the time selected on ALARM 1 TIME 1. Program zero to disable this function.
A2t1	ALARM 2 TIME 1: Defines the time (6500 sec. max.) during which the alarm 1 output will be <b>ON</b> when alarm 1 is active. Program zero to disable this function
A2t2	ALARM 2 TIME 2: Defines the time during which the alarm 2 output will be, after being <b>ON</b> during the time selected on ALARM 2 TIME 1. Program zero to disable this function. Table 4 shows the advanced features that can be achieved with these time functions.

7.6 CONFIGURATION CYCLE



type	INPUT TYPE: Selects the input signal type to be connected to the process variable input. Refer to Table 1. <b><i>This is the first parameter to be set.</i></b>
dppo	DECIMAL POINT POSITION: For input types 16, 17, 18 or 19 only. Selects the decimal point position to be viewed in both PV and SV.
vn /t	TEMPERATURE INDICATION IN °C OR °F: Selects the display indication to be in °C or °F. Only available if input type is other than 16, 17, 18 or 19.
offs	SENSOR OFFSET: Offset value to be added to the PV to compensate sensor error. Default value: zero.
spl l	SET POINT LOW LIMIT: <ul style="list-style-type: none"> <li>Linear inputs: Sets the lower range for SV and PV indication.</li> <li>T/C and Pt100 inputs: sets the lower range for SV.</li> </ul>
spxl	SET POINT HIGH LIMIT: <ul style="list-style-type: none"> <li>Linear inputs: Sets the upper range for SV and PV indication.</li> <li>T/C and Pt100 inputs: sets the upper range for SV.</li> </ul>
bavd	DIGITAL COMMUNICATON BAUD RATE SELECTION: 0: 1200bps; 1: 2400bps; 2: 4800bps; 3: 9600bps; 4: 19200bps.



addr	SLAVE ADDRESS SELECTION: Identifies a slave in the network. The possible address numbers are from 1 to 247.
------	---

7.7 I/O CYCLE (INPUTS AND OUTPUTS)

I/O 1	I/O 1 FUNCTION: Selects the I/O function to be used at I/O 1 (relay 1). Options 0 to 6 are possible for this output. It is normally used as option 5, PWM main control output. Refer to Table 2 for functions.
I/O 2	I/O 2 FUNCTION: Selects the I/O function to be used at I/O 2 (relay 2). Options 0 to 6 are available. This output is normally used as alarm output. See Table 2 for functions.
I/O 3	I/O 3 FUNCTION: Selects the I/O function to be used at I/O 3 (option 1). I/O 3 can be a relay output or a digital input/output. Functions 0 to 11 are available. Refer to Table 2 for functions. The presence of this I/O option is detected by the controller and the prompt menu will only be shown if the expansion option is available.
I/O 4	I/O 4 FUNCTION: Selects the I/O function to be used at I/O 4 (option 2). I/O 4 can be a digital input/output. Functions 0 to 11 are available. Refer to Table 2 for functions. The prompt menu will only be shown if the expansion option is present.
I/O 5	I/O 5 FUNCTION: Selects the I/O function to be used at I/O 5 (Analog Output). Functions 0 to 18 are available (See Table 2). This option is normally used for main control output or PV analog retransmission.

7.8 CALIBRATION CYCLE

All input and output types are factory calibrated. This cycle should only be accessed by experienced personnel. If in doubt do not press the  or  keys in this cycle.

Inl (	INPUT LOW CALIBRATION: Sets the Process Variable low calibration (offset). Several keystrokes at  or  might be necessary to increment one digit.
Inx (	INPUT HIGH CALIBRATION: Sets the Process Variable span calibration (gain).
ovl (	OUTPUT LOW CALIBRATION: Sets the analog current output low calibration (offset).
Ovx (	OUTPUT HIGH CALIBRATION: Sets the analog current output span calibration (gain).
uj	COLD JUNCTION OFFSET CALIBRATION: Sets the cold junction offset calibration.
xtyp	HARDWARE TYPE: Configures the controller to recognize the actual installed optional hardware (accessories). The parameters menu will show the parameters relative to the optional hardware: 0 - no optionals or c/ RS485 only 1 - relay 3 (I/O 3) 2 - Digital I/O (2 inputs/outputs) 3 - Heater break protection (option).

8 CONTROL # 2

The N1100HC incorporates a second control output with proportional action. This second control output is intended primarily for refrigeration, since the control #1 is normally used for heating.

The Control #2 cycle of parameters is listed in 7.3 above.

If the application requires both heat and cool outputs, configure the parameters **Act=ref** e **ACT2=dir** and set the overlap (**OLAP**) accordingly, as follows.

1) **OLAP** > 0; both outputs may be delivering power to the system.

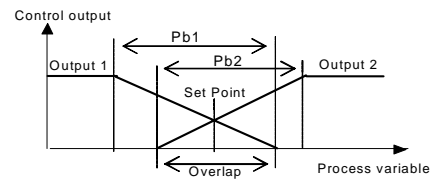

**OLAP** < 0; for setting a dead-band.

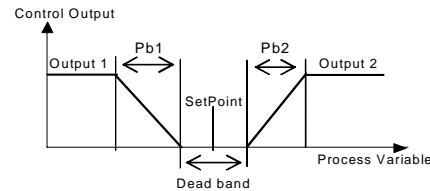

**OLAP** = 0; no superposition or dead-band for the outputs.

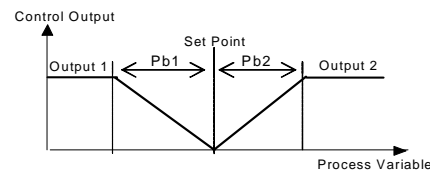

Output 2 has independent proportional band and PWM period, as well as maximum and minimum limits for the output.

If Pb2=0, the control #2 becomes ON-OFF, and the OLAP parameter becomes the Hysteresis for the control #2.

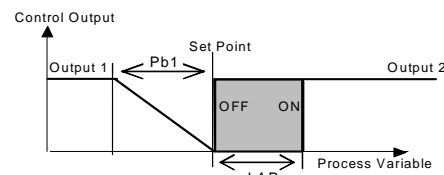

9 RAMP AND SOAK PROFILE PROGRAM

Four ramp and soak profiles with up to 5 segments each can be programmed. Longer profiles of up to 20 segments can be created by linking 2 or more profiles.

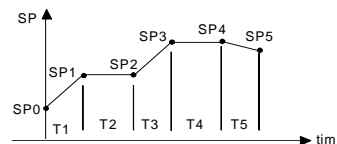

Fig. 1 - Example of a complete ramp and soak profile

To execute a profile with fewer segments just program 0 (zero) for the time intervals that follow the last segment to be executed.

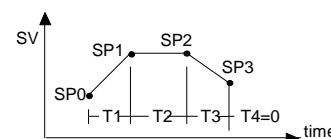

Fig. 2 - Example of a profile with fewer segments. (T4 is set 0)

The program tolerance "**Ptol**" defines the maximum deviation between PV and SV for the execution of the profile. If this deviation is exceeded, the program will be interrupted until the deviation falls to within the tolerance band.

Programming 0 (zero) at this prompt disables the tolerance and the profile execution will not to be halted even if PV does not follow SV (time priority as opposed to SV priority).

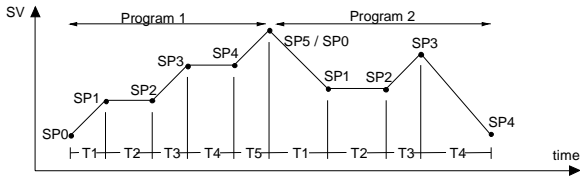

Fig. 3 - Example of two linked programs

The ramp and soak event function is used to activate alarms at any segment of program 1. This applies only to program 1.

To enable this event function the alarms to be activated must be selected for **rs** function and are programmed at the **PE 0** to **PE 5** prompts. The number to be programmed at the prompt defines the alarms to be activated (Table 5).

Table 5 - Event codes for ramp and soak

Code	Alarm 1	Alarm 2	Alarm 3	Alarm 4
0				
1	X			
2		X		
3	X	X		
4			X	
5	X		X	
6		X	X	
7	X	X	X	
8				X
9	X			X
10		X		X
11	X	X		X
12			X	X
13	X		X	X
14		X	X	X
15	X	X	X	X

To configure and execute a ramp and soak program:

- Program the tolerance value, SV, time and event.
- If any event alarm is required program the ramp and soak event function.
- Set the control mode to automatic.
- Select ramp and soak program to be executed at prompt **Prn** (0 to 4)
- Start control at the run prompt **rvn** by selecting **YES**.

Before executing the program the controller waits for PV to reach the first set point **SP0** if **Ptol** is different than zero.

Should any power failure occur the controller resumes at the beginning of the segment it was previously.

## 10 AUTO TUNE

During auto tune the process is controlled in ON/OFF mode at the programmed SetPoint (SV). Depending on the process characteristics large oscillations above and below SV may occur and auto tuning may take several minutes to be concluded.

The recommended procedure is as follows:

- Disable the control output at the **rvn** prompt by selecting **NO**.
- Select auto mode operation at the **Avto** prompt by selecting **YES**.
- Disable the ramp and soak function (select **NO**) and program a new SV value other than the present PV (close to the desired set point).
- Enable auto tuning at the **Atvn** prompt by selecting **YES**.
- Enable the control output at the **rvn** prompt by selecting **YES**.

During the auto tune procedure the soft-start function will not operate and large oscillations will be induced around the setpoint. Make sure the process can accept these oscillations and fast control output changes.

If auto tuning results are not satisfactory refer to Table 6 for manual fine tuning procedure.

Table 6 - Suggestions for manual tuning of PID parameters

PARAMETER	RESPONSE	SOLUTION
Proportional Band	Slow Response	Decrease
	Large Oscillation	Increase
Integral Rate	Slow Response	Increase
	Large Oscillation	Decrease
Derivative Time	Slow Response or Instability	Decrease
	Large Oscillation	Increase

## 11 SERIAL COMMUNICATION

An optional RS485 serial communication interface is available which allows up to 247 controllers in a network to communicate to a master device.

### RS485 Interface

- Compatible signals with RS485 standard;
- Two-wire connection from master to up to 247 slave controllers in a multidrop bus;
- Maximum communication distance: 1000 meters;

### General Characteristics

- Optically isolated serial interface
- Programmable Baud rate: 1200, 2400, 4800, 9600 or 19200bps.
- Data Bits: 8
- Parity: None
- Stop Bits: 1

# Kurzinformation - Regler N1100-HC

Als erstes müssen die Parameter in der Konfigurations- und der Ausgangs-Ebene eingestellt werden!

Funktion der Tasten	
	Programm-Taste Vorwärtsschritt in der aktuellen Ebene
	Rückschritt-Taste Rückschritt in der aktuellen Ebene
	Auf-Taste Parameterwert wird vergrößert
	Ab-Taste Parameterwert wird verkleinert
-----	
+	gleichzeitig anwählen der nächsten Ebene (zuerst  dann  betätigen)

## Reihenfolge der einzelnen Ebenen

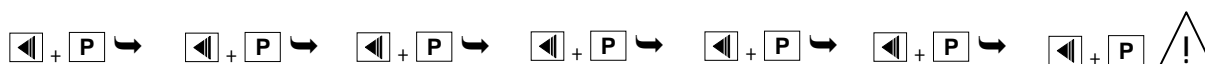

Betriebs-Ebene	Regelparameter- und Alarmwert-Ebene	Regelausgang 2-Ebene	Programm- und Rampen-Ebene	Alarmart-Ebene	Konfigurations-Ebene	Ausgangs-Ebene	Kalibrier-Ebene*
 	atvn	Pb2	Pr n	Fva1	type	io 1	Inl (
avto	Pb1	ol ap	ptol	Fva2	dppo	io 2	Inx (
 	xyst	(t2	Psp0 bis Psp5	Fva3	vni t	io 3	ovl (
Pr n	' ir	Act2	Pt1 bis Pt5	Fva4	offs	io 4	Ovx (
rvn	dt	02ll	Pe1 bis Pe5	bla1	spl l	io 5	(j l
	(t1	02xl	lp	Bl a2	spxl		xtyp
	act			Bl a3	bavd		
	bi as			Bl a4	addr		
	01ll			xya1			
	01xl			Xya2			
	Sfst			Xya3			
	Spa1			Xya4			
	Spa2						
	Spa3						
	Spa4						



\* Die Kalibrier- Ebene sollte nur von geschultem Personal angewählt werden!

Hierzu müssen die Tasten min. 3 Sekunden lang betätigt werden.

**Einstellungen die durch B+B Thermo-Technik vorgenommen wurden, könnten hier gelöscht werden!**

Wenn Sie versehentlich die Kalibrier-Ebene angewählt haben:

- verwenden Sie in keinem Fall die Tasten oder .
- verlassen Sie die Ebene durch mehrfaches betätigen der Taste .

ANSCHLUSSBELEGUNG REGLER N1100-HC C/3, ARTIKELNUMMER 0556 0104

Oben Ansicht auf die Rückseite

Ausgang I/O3  
Relais max. 3A, 250V AC,  
ohmsche Last

Versorgungsspannung  
85...250 V AC,  
50-60Hz

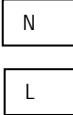

Ausgang I/O2  
Relais max. 3A,  
250V AC, ohmsche Last

Ausgang I/O1  
Relais max. 3A,  
250V AC, ohmsche Last

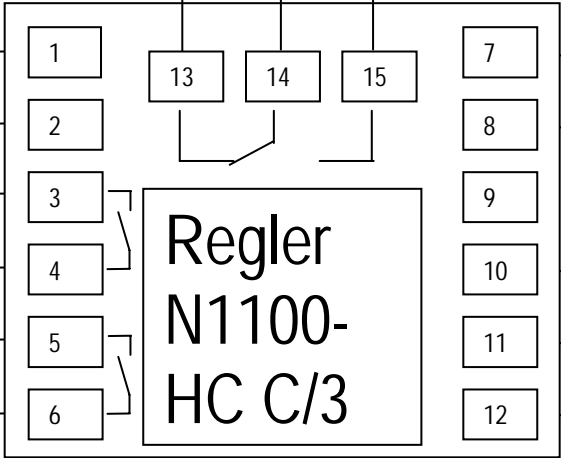

**Wichtig:**  
Der Regler ist entsprechend dem Anschlussbild anzuschließen.  
Es ist sicherstellen, dass die Netzspannung den Angaben auf dem Regler entspricht und der Anschlusswert der am Regler angeschlossenen Verbraucher den vorgesehenen Höchstwert nicht überschreitet.  
Da der Regler für einen permanenten Anschluss vorgesehen ist, verfügt er weder über Schalter noch über interne Schutzvorrichtungen gegen Überstrom.  
Daher sind geeignete Absicherungs- und Abschaltvorrichtungen vorzusehen, die im Störfall die Stromversorgung zum Regler unterbrechen.  
Die örtlichen Bestimmungen sind strengstens zu beachten.

